

Foreword

Thank you for choosing CDI-SPD series photovoltaic water pump driver produced by Delixi (Hangzhou) Inverter Co., Ltd.

Before using CDI-SPD series photovoltaic water pump driver (hereinafter referred to as “the Product”), please read the manual carefully in order to ensure the proper use. Improper use may result in the equipment’s abnormal operation, malfunction, decrease of service life and even personal injury accident. Therefore, please do read the manual carefully before use and use the Product strictly according to the manual. The manual is a standard file which must be kept properly after reading for further repairing and maintenance of the Product in the future.

Besides the operating instructions, the manual also provides wiring diagram for your reference. If having difficulties or special requirements for usage of the Product, please feel free to contact our local offices or dealers or call our customer service center of the headquarters directly. We will offer dedicated service to you. We may change the contents of this Manual without a prior notice.

Please confirm the followings seriously when unpacking the Product:

1. Check if the Product is damaged, components and parts are damaged and drop and the body is collided in the transportation process.
2. Check if the rated value labeled on the nameplate of the Product accords with your order requirements and if the packaging box contains the machine that you order, product certificate, operation manual and warranty card.

We are strict in the manufacture, packaging and delivery. For any inspection omissions, please contact us or your supplier to solve the problem.

Table of Contents

Table of Contents	
Foreword.....	I
Chapter I Safety Operation and Attentions	1
1.1 Acceptance	1
1.2 Safety Operation Attentions	2
Chapter II Product Information	3
2.1 Nameplate Data and Naming Rule	3
2.2 Product Specification	4
2.3 Product List	4
2.4 Appearance and Installation Dimension	5
2.5 Daily Maintenance and Repairing	9
Chapter III Installation and Wiring.....	11
3.1 Installation Site and Space.....	11
3.2 Standard Wiring.....	13
3.2.1 Description of the terminals of frequency inverter.....	14
3.2.2 Wiring reference for the main circuit and control circuit is as shown in the table below.....	16
3.3 Earthing.....	17
Chapter IV Keyboard Operation and Running	14
4.1 Selection of Operation Mode.....	18
4.2 Test Run and Inspection	18
4.2.1 Precautions and inspection prior to test run	18
4.2.2 Test Run	18
4.3 Keyboard Operation Method	19
4.3.1 Keys and functions of keyboard.....	19
4.3.2 Methods to view/give parameters (with digital keyboard)	21
4.3.3 Keyboard monitoring data	22
Chapter V Functional Parameters Table	23
5.1 Basic Functions of F28 Group	24
Chapter VI Troubleshooting	27
Appendix 1 Recommended Configuration of Solar Cell Modules	29

Chapter I Safety Operation and Attentions

Please read this manual carefully before installation, operation, maintenance and inspection of the Product.

Please read this chapter before using the Product in order to ensure personal, equipment and property safety. Attentions related to safety operation in the manual are classified into “warning” and “cautions”.



Warning

: Potentially dangerous condition, which maybe cause severe body injuries or dead if relevant requirement is ignored.



Cautions

: Potentially dangerous condition, which maybe cause middle, light injuries or devicedamage if relevant requirement is ignored, it also applies to unsafe operation.

1.1 Acceptance



The items in the table below must be inspected:

Items Inspected	Note
1. Is the model of frequency inverter consistent with order?	Check the Model indicated on the nameplate on one side of the frequency inverter.
2. Is there any damage to the components?	Survey the external appearance of the frequency inverter and make sure that no damage has occurred during
3. Are the components properly fastened?	Take off front cover of frequency inverter and use proper tools to inspect all visible components.
4. Is the user’s manual received?	User’s manual of frequency inverter

Please contact us or our agent if any of the items above fails to pass the acceptance.

Chapter I Safety Operation and Attentions

1.2 Safety Operation Attentions

 <p>Warning</p>  <p>Anti-static</p>	1. Installation and maintenance should be performed by professional only.
	2. Verify that rated voltage of the frequency inverter should conform with voltage level of AC power supply. Otherwise it shall cause hurt to human body or fire accident.
	3. Don't connect main circuit power with output terminals U, V and W. The connection will damage equipment, thus warranty card will be invalid.
	4. Don't connect input power until panel is well installed. Do not remove the cover when it is powered; otherwise, electric shock may occur.
	5. Don't touch high voltage terminal within frequency inverter under power-on status; otherwise, electric shock may occur.
	6. Maintain the frequency inverter after powering off it for at least 15 minutes because it has plenty of capacitance energies. At the moment, charging indicator light will be off or confirm the positive and negative Bus line voltages are under 36V; otherwise, electric shock can occur.
	7. Don't turn on or off line and connector when the circuit is powered on. Otherwise, personal injury may occur.
	8. Electronic components can be easily damaged by static electricity so please avoid touching them.
	9. This frequency inverter should not undergo voltage withstand test, which might result in damages to the semiconductor devices in it.
	10. Cover plate must be covered up before power on; otherwise, electric shock and explosion can occur.
	11. Never confuse the input and output terminals. Otherwise, explosion or damage to the property might occur.
	12. For frequency inverter of which storage period exceeds half year, please increase the input voltage gradually by using regulator, to prevent from electric shock and explosion.
	13. Don't operate the frequency inverter with wet hands; otherwise, electric shock may occur.
	14. All parts should be replaced by professional only. It is strictly prohibitive to remain stub or metal object in machine, to prevent from fire.
	15. After replaced control board, please perform relevant parameter setting before operation to prevent from damage of materials.
 <p>Cautions</p>	1. If the motor is used for the first time or has been in leisure for a long time, remember to check its insulation first. It is advisable to use a 500V megger. Make sure the insulation resistance should not be less than 5 MΩ.
	2. Please consider the tolerance of mechanical device if it needs running above 50 Hz.
	3. In the regions with an altitude above 1,000 m, the heat dissipation effect of frequency inverter will be reduced due to thin air so it must be used with a reduced capacity. Reduce capacity by 1% for every 100 m after the altitude exceeds 1,000 m.
	4. Do not start or stop the frequency inverter with contactors. Otherwise, damage might occur to the equipment.
	5. Do not modify factory set value of frequency inverter without authorization, or damage might be caused.

Chapter II Product Information

2.1 Nameplate Data and Naming Rule

Nameplate data: Take CDI-SPDG1R5S2 as an example:

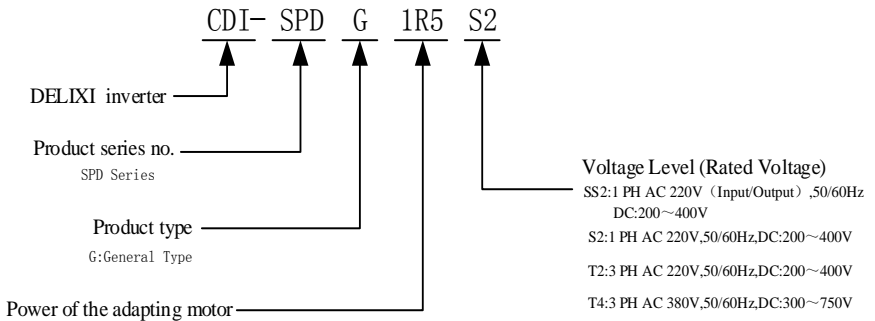
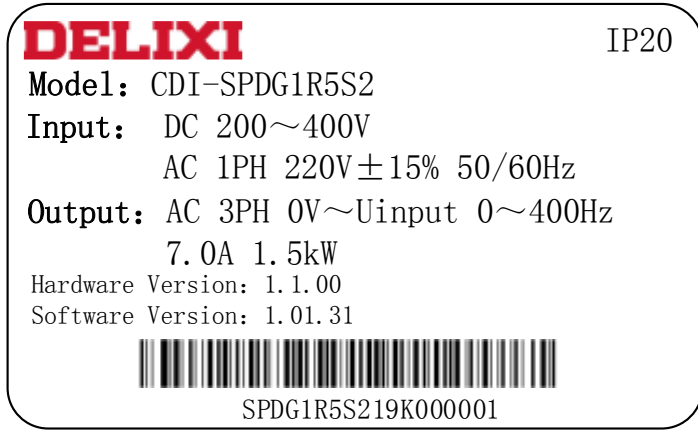

Chapter II Product Information

2.2 Product Specification

Machine Type	-SS2 Product	-S2 Product	-T2 Product	-T4 Product
AC input voltage (V)	220 (±15%) (1PH)		220 (±15%) (3PH)	380 (±15%) (3PH)
Max. DC voltage (V)	440	440	440	800
Starting voltage (V)	200	200	200	300
Min. working voltage (V)	150	150	150	250
Range of DC input voltage recommended (V)	200~400	200~400	200~400	300~750
Recommended MPP voltage (V)	330	330	330	550

2.3 Product List

Model of Frequency Inverter	Rated Input Current (A)	Rated Output Current (A)	Adaptive Motor (kW)
CDI-SPDG0R4SS2	6.5	5.0	0.4
CDI-SPDG0R7SS2	9.5	7.0	0.7
CDI-SPDG1R5SS2	15.7	10.0	1.5
CDI-SPDG2R2SS2	27.0	14.0	2.2
CDI-SPDG4R0SS2	32.8	17.0	4.0
CDI-SPDG0R4S2	6.5	3.0	0.4
CDI-SPDG0R7S2	9.5	5.0	0.7
CDI-SPDG1R5S2	15.7	7.0	1.5
CDI-SPDG2R2S2	27.0	10.0	2.2
CDI-SPDG4R0S2	32.8	17.0	4.0
CDI-SPDG4R0T2	18.5	17.0	4.0
CDI-SPDG0R7T4	3.4	3.0	0.7
CDI-SPDG1R5T4	5.0	4.5	1.5
CDI-SPDG2R2T4	6.8	6.0	2.2
CDI-SPDG4R0T4	10.5	9.5	4.0
CDI-SPDG5R5T4	15.5	13.0	5.5
CDI-SPDG7R5T4	20.5	17.0	7.5
CDI-SPDG011T4	26	25.0	11
CDI-SPDG015T4	35	32.0	15
CDI-SPDG018.5T4	38.5	37.0	18.5
CDI-SPDG022T4	46.5	45.0	22
CDI-SPDG030T4	62	60.0	30
CDI-SPDG037T4	76	75.0	37
CDI-SPDG045T4	92	90.0	45
CDI-SPDG055T4	113	110.0	55
CDI-SPDG075T4	157	152.0	75
CDI-SPDG090T4	180	176.0	90
CDI-SPDG110T4	214	210.0	110

Ordering instruction:

Chapter II Product Information

Please specify the corresponding model and specification of the products when placing an order. For any special requirements, please contact us for negotiation.

2.4 Appearance and Installation Dimension

Model1

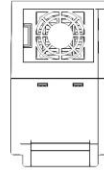
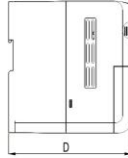
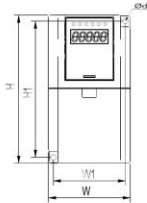
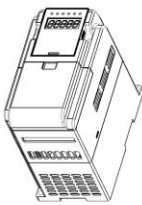

Model	W	W1	H	H1	D	Ød
CDI-SPDG0R4SS2	84	74	152	140	141	5.5
CDI-SPDG0R4S2						
CDI-SPDG0R7S2						
CDI-SPDG0R7T4						
CDI-SPDG1R5T4						

Unit:mm

Main Circuit Wiring Diagram:

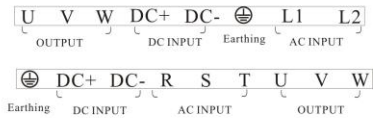

Note:

1. Plastic shell
2. The ordering of the terminals is subject to material object

Model2

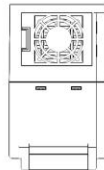
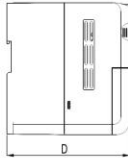
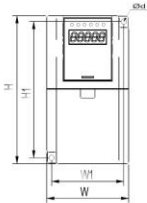
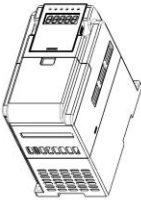

Model	W	W1	H	H1	D	Ød
CDI-SPDG0R7SS2	105	95	165	153	154	5.5
CDI-SPDG1R5SS2						
CDI-SPDG1R5S2						
CDI-SPDG2R2S2						
CDI-SPDG2R2T4						
CDI-SPDG4R0T4						

Unit:mm

Main Circuit Wiring Diagram:

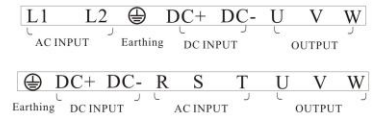

Note:

1. Plastic shell
2. The ordering of the terminals is subject to material object

Chapter II Product Information

Model3

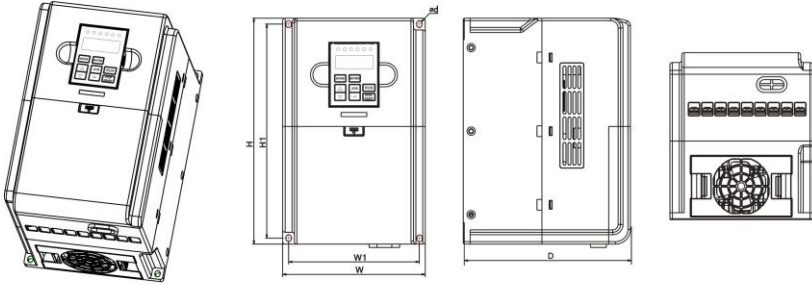

Model	W	W1	H	H1	D	Ød
CDI-SPDG2R2SS2						
CDI-SPDG4R0SS2						
CDI-SPDG4R0S2	145	133	230	218	170	5.5
CDI-SPDG4R0T2						
CDI-SPDG5R5T4						
CDI-SPDG7R5T4						

Unit:mm

Main Circuit Wiring Diagram:

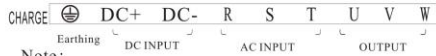

Note:

1. Plastic shell
2. The ordering of the terminals is subject to material object

Model4

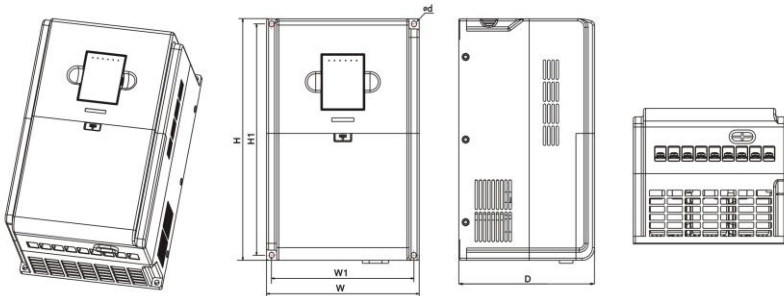

Model	W	W1	H	H1	D	Ød
CDI-SPDG011T4	180	168	285	273	160	5.5
CDI-SPDG015T4						

Unit:mm

Main Circuit Wiring Diagram:



Note:

1. Plastic shell
2. The ordering of the terminals is subject to material object

Model15

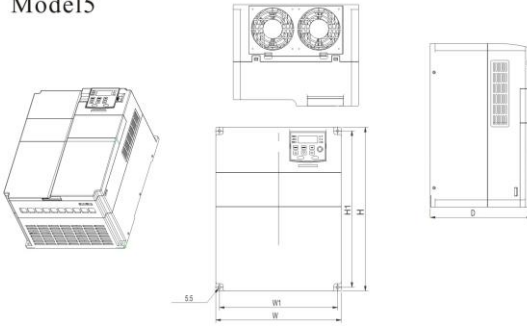

Model	W	W1	H	H1	D	∅d
CDI-SPDG018.5T4	260	245	340	325	210.5	5.5
CDI-SPDG022T4						

Unit:mm

Main Circuit Wiring Diagram:



Note:

The ordering of the terminals is subject to material object

Model16

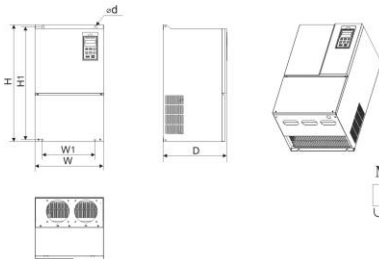

Model	W	W1	H	H1	D	∅d
CDI-SPDG030T4	250	160	430	415	220	7
CDI-SPDG037T4						

Unit:mm

Main Circuit Wiring Diagram:

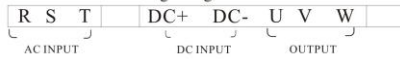

Note:

The ordering of the terminals is subject to material object

Chapter II Product Information

Model7

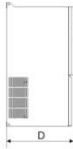
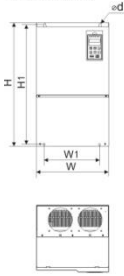

Model	W	W1	H	H1	D	ød
CDI-SPDG045T4	300	240	530	515	270	ø9
CDI-SPDG055T4						

Unit:mm

Main Circuit Wiring Diagram:



Note:

The ordering of the terminals is subject to material object

Model8

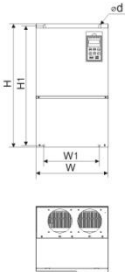

Model	W	W1	H	H1	D	ød
CDI-SPDG075T4	340	260	580	565	313	ø9
CDI-SPDG090T4						
CDI-SPDG110T4						

Unit:mm

Main Circuit Wiring Diagram:



Note:

The ordering of the terminals is subject to material object

2.5 Daily Maintenance and Repairing

(1) Daily maintenance

The influence such as environmental temperature, humidity, dust and vibration may result in aging of the internal components of frequency inverter, which should cause potential fault of frequency inverter or reduction of its service life. Therefore, it is necessary to perform daily maintenance and regular inspection with the frequency inverter.

Daily inspection item:

- A Check if the sound of motor running has any abnormal change.
- B Check if there is any vibration in motor running.
- C Check if the installation environment of frequency inverter is changed.
- D Check if the cooling fan of frequency inverter works normally.

Daily cleaning:

- A Keep frequency inverter always clean and tidy.
- B Clean surface dust on the frequency inverter effectively in order to prevent dust from entering the frequency inverter, especially metal dust.
- C Clean oil dirt of frequency inverter's cooling fan effectively.

(2) Regular inspection

Please inspect places that can be hardly inspected regularly.

Regular inspection item:

- A Inspect and clean air flue regularly.
- B Inspect if the screw is loose.
- C Inspect if the frequency inverter is corroded.
- D Inspect if there is arc on surface connecting terminal.

(3) Replacement of vulnerable parts

The vulnerable parts of the frequency inverter include cooling fan and filter electrolytic capacitor, the service life of which closely depend on operating environment and maintenance condition.

Users can confirm replacement period according to running time.

A Cooling fan

Possible damage reasons: Bearing abrasion and blade aging.

Judgment standard: Confirm if the fan blade has cracks and abnormal vibration sound when starting.

B Filter electrolytic capacitor

Possible damage reasons: Input power with low quality, high environment temperature, frequent load modulation and electrolyte aging.

Judgment standard: Confirm if the liquid leaks and safety valve has protruded; measurement of electrostatic capacity and insulation resistance.

(4) Storage of frequency inverter

After purchased the device, please pay attention to following points while

Chapter II Product Information

storing it:

A Please store it in original package as much as possible.

B Long term storage should cause aging of electrolytic capacitor. Make sure to electrify it once every half a year for at least 5 hours and to raise voltage to rated value slowly via voltage regulator.

(5) Warranty of frequency inverter

Maintenance free is limited to the frequency inverter only.

We provide life-long paid service for our products, whenever and wherever they are used.

We bear the responsibilities of repair, replacement and return at most for the product once quality or product accident happens. If users need more responsibility compensation warranties, please place insurance at the property insurance company in advance.

Warranty service should be effective in 18 months after bar code date.

For fault caused in following reasons, a pay-needed maintenanceservice only is available even warranty term is effective:

A Faults caused by incorrect operation (subject to user's manual) or unauthorized repair and refitting.

B Problems caused by using the frequency inverter beyond requirements of standard and specification.

C Damage caused by accidental drop and improper handling after purchase.

D Aging or fault caused by severe environment.

E Damage caused by natural disasters such as earthquake, fire disaster, wind, lightning stroke, abnormal voltage or reasons happening together with disasters.

F Damage in the transportation process (Notes: Transportation mode is designated by user of themselves. We could assist agent to conduct transfer of goods).

G When brand, trademark, serial number and nameplate marked by manufacturers are damaged or can't be recognized.

H Failure to pay off fund according to purchase contract.

I Failure to describe actual conditions relating to installation, wiring, operation, maintenance, or other condition to the Company.

For the repair, replacement and return services, customers need to send the product back to us. We will provide the corresponding service after confirming the responsible party.

We still have the ownership of the product for which the buyer doesn't pay off the price or pay the residual fund in time. In such case, we do not undertake the above responsibilities and the buyer cannot propose any disagreement.

All relevant service fees shall be calculated in accordance with the identical standards of the factory. In the event that an agreement or a contract exists, its priority shall be performed.

Chapter III Installation and Wiring

3.1 Installation Site and Space

Installation site:

 Warning	1. Avoid direct sunlight and outdoor direct use.
	2. Don't use it under corrosive gas and liquid environment.
	3. Don't use it under oil fog and splashing water environment.
	4. Don't use it under salt fog environment.
	5. Don't use it under raining and moist environment.
	6. Please equip the unit with filters device if metal dust or fiber wadding existing in air.
	7. Avoid power noise, such as electric welding machine and high-power electrical equipment, which can impact operation of the equipment.
	8. Radioactive materials can influence use of the Product.
	9. Avoid flammable materials, thinner and solvent.
Environment	Environment temperature: -10°C~+40°C
	Storage temperature: -20°C~+65°C
	Environment humidity: 90% RH at maximum (noncondensing)
	Height: Under 1,000 m. Reduce capacity by 1% for every 100 m after the altitude exceeds 1,000 m.
	Vibration: No greater than 5.9 m/s ² (0.6 g) at maximum.
	Installation direction: Please install the product vertically in order not to affect the heat dissipation effect of frequency inverter.

For sound performance and long service life, the frequency inverter shall be installed according to the above installation environment suggestions to prevent damages.

Installation space:

When frequency inverters are installed vertically, enough heat dissipation space shall be reserved in order to ensure effective cooling.

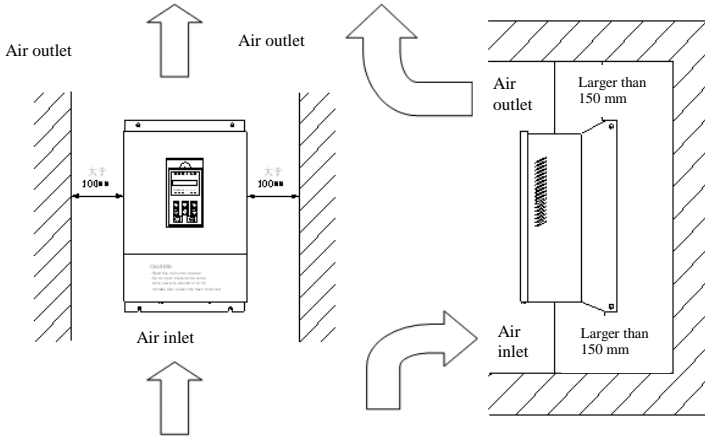



Installation Space of Frequency Inverter

 Cautions	1. Necessary clearance for open-frame type (IP00) and enclosed wall-mounted type (IP20) is the same at the top/bottom and both sides.
	2. Air temperature at the permitted inlet of frequency inverter: -10°C~+40°C.
	3. Enough heat dissipation space shall be reserved in the upper and lower areas in order to ensure smooth air intake and emission of frequency inverter.
	4. Don't let foreign objects fall inside air duct during installation lest fan damage.
	5. Add filtering device at air intake when silk fibers fly or it is very dusty.

3.2 Standard Wiring

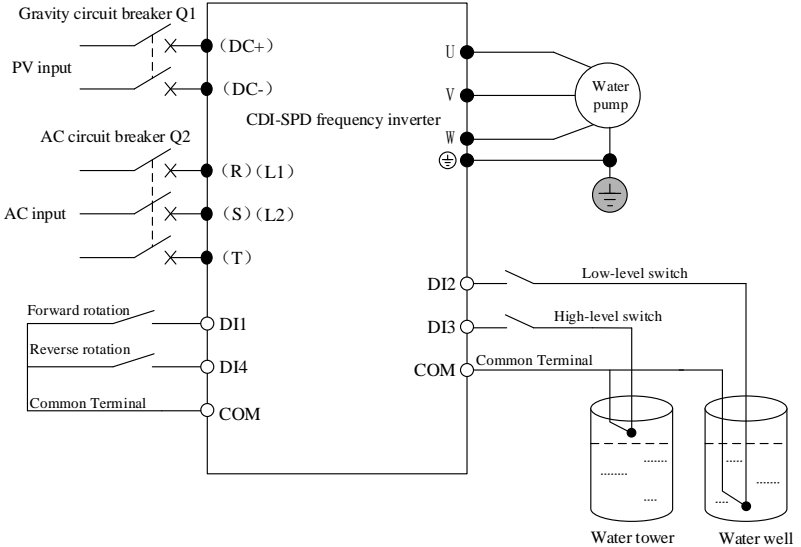
See the standard wiring diagram of the main circuit and control circuit of the Product in the figure below:



 Cautions	<ol style="list-style-type: none"> 1. DC circuit breaker Q1 must be installed as the protection switch of PV DC input. 2. Frequency inverter must not be in AC and DC connection at the same time. If it requires AC/DC connection at the same time, switching control circuit shall be configured externally. 3. Special PV combiner boxes shall be used for the parallel connection of components. 4. When PV cell module is more than 10 m from frequency inverter, Type II lightning arrester shall be configured at DC input end. 5. When water pump is more than 50 m from frequency inverter, it is suggested to select output reactor. 6. Self-running upon power-up is defaulted for frequency inverter. If it needs to configure parameters, please set in strict accordance with the instruction steps of Chapter IV. 7. Tighten terminal screws according to the specified tightening torque. 8. Make sure the earthing terminals have been earthed before connecting the main circuit. 9. Terminal arrangement sequence shall be subject to physical objects.
--	---

3.2.1 Description of the terminals of frequency inverter

Description of the Main Circuit Terminals of Frequency Inverter:

Identification	Name	Function Description
R, S, T (L1, L2)	AC input	3-phase (single-phase) AC input terminal, connected to power grid
DC+, DC-	PV DC input	Input terminal of PV cell panel
U, V, W	Output of frequency Inverter	3-phase (single-phase) AC output terminal, generally connected to the motor of water pump
	Safe protection earthing	Safe protection earthing terminal; each machine must be earthed reliably

Description for -SS2 single-phase output models

1) Generally, the output terminals U and W of the inverter connect to the phase cables of the single-phase motor.

2) If the single-phase pump cannot be started, the two-phase control method must be used, and the start-up and running capacitors (if any) of the motor must be removed. The figure below shows the internal wiring of the common single-phase motor. In the figure, L1, L2, C1, and C2 indicate the running winding, start-up winding, running capacitor, and start-up capacitor. When the motor speed exceeds 75% of the rated speed, the start-up capacitor is switched off.

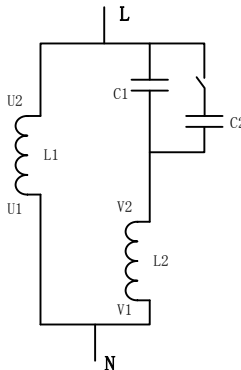

Internal wiring of the single-phase motor winding after removing the starting and running capacitor:

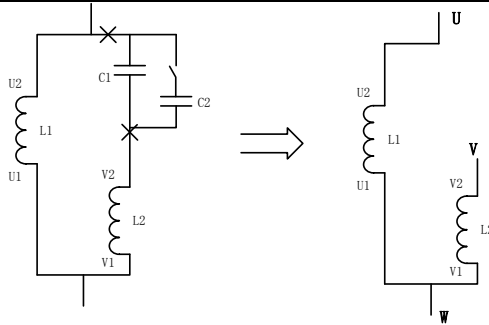

U1 and V1 are the common terminals of the windings. Connect them to the output terminal W of the solar pumping inverter. Connect U2 to the output terminal U of the inverter. Connect V2 to the output terminal V of the inverter. (Note: Use the screws equipped with the inverter.) Now F28.39=1.

Description of the Control Circuit Terminals of Frequency Inverter:

Classification	Terminal	Name	Function Description
Digital quantity input	DI1	Forward running	DI1: Forward running of frequency Inverter
	DI2	Low-level switch	DI2: level switch (low-level switch) connected to the normally on contact by default
	DI3	High-level switch	DI3: level switch (high-level switch) connected to the normally on contact by default
	DI4	Reverse running	DI4: Reverse running of frequency Inverter
T1 relay	T1A	Failure output	TA-TB is normally on TTA-TC is normally off Driving capability: AC 250 V below 3 A DC 30 V below 3 A
	T1B		
	T1C		
+24 V power supply	COM	24 V power output	Provide DC 24 V power voltage to the external. Driving capability: Maximum output current 300 mA
	+24V		

Chapter III Installation and Wiring

3.2.2 Wiring reference for the main circuit and control circuit is as shown in the table below

Model of Frequency Inverter	Wire Gauge of Main Circuit (mm ²)		Wire Gauge of Main Circuit (mm ²)
	DC+/DC-, R/S/T, U/V/W	 PE	
CDI-SPDG0R4SS2	2.5	2.5	1.0
CDI-SPDG0R7SS2	2.5	2.5	1.0
CDI-SPDG1R5SS2	4	4	1.0
CDI-SPDG2R2SS2	4	4	1.0
CDI-SPDG4R0SS2	6	6	1.0
CDI-SPDG0R4S2	2.5	2.5	1.0
CDI-SPDG0R7S2	2.5	2.5	1.0
CDI-SPDG1R5S2	2.5	2.5	1.0
CDI-SPDG2R2S2	4	4	1.0
CDI-SPDG4R0S2	6	6	1.0
CDI-SPDG4R0T2	6	6	1.0
CDI-SPDG0R7T4	2.5	2.5	1.0
CDI-SPDG1R5T4	2.5	2.5	1.0
CDI-SPDG2R2T4	2.5	2.5	1.0
CDI-SPDG4R0T4	4	4	1.0
CDI-SPDG5R5T4	4	4	1.0
CDI-SPDG7R5T4	6	6	1.0
CDI-SPDG011T4	6	6	1.0
CDI-SPDG015T4	10	10	1.0
CDI-SPDG018.5T4	16	16	1.0
CDI-SPDG022T4	16	16	1.0
CDI-SPDG030T4	25	16	1.5
CDI-SPDG037T4	25	16	1.5
CDI-SPDG045T4	35	16	1.5
CDI-SPDG055T4	35	16	1.5
CDI-SPDG075T4	50	25	1.5
CDI-SPDG090T4	70	35	1.5
CDI-SPDG110T4	120	60	1.5

3.3 Earthing

1. Earthing resistance:
200 V level: 100 Ω or below
400 V level: 10 Ω or below

2. Don't earth frequency Inverter, electric welder, motor or other large-current electrical equipment commonly. Make sure all earth wires inside conduit are laid separately from the leads of large-current electrical equipment.

3. Use earth wires up to the specified standard and shorten their length as much as possible.

4. When several frequency Inverters are used in a row, please earth the device as shown in Fig. (a) and Don't make earth wires form a circuit as shown in Fig. (c).

5. Frequency Inverters and motors shall be earthed according to the connections given in Fig. (d).

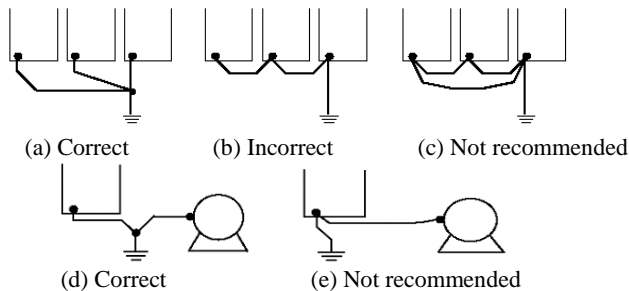

6. Wiring inspection:

Inspect the following items after installation and wiring are completed.

A. Check if the wiring is correct.

B Check if there is broken wire residues or screws left inside the device.

C Check if the screws are tightened firmly.

D Check if the naked leads on terminal contact with other terminals.



Chapter IV Keyboard Operation and Running

4.1 Selection of Operation Mode

The Product is provided with three control modes, including keyboard running, terminal running and self-running upon power-up. Users can select corresponding control mode according to field environment and working needs. See 5.1 for specific selections.

4.2 Test Run and Inspection

4.2.1 Precautions and inspection prior to test run

 Danger	1. Don't turn power on until the front cover is installed and Don't remove the outer cover when power is on; otherwise, electric shock will be caused.
	2. Don't get close to frequency inverter or load when restart is selected, as the device will restart suddenly after it is just stopped. (Even if frequency inverter restarts, its mechanical system can ensure personal safety). Otherwise, personal injuries will be caused.
	3. As stop button will become not working after function setting, a separate emergency stop button should be installed; otherwise, personal injuries will be caused.
 Cautions	1. Don't touch the radiator or resistor since it is hot; otherwise, burns will be caused.
	2. As low-speed running can easily become high-speed running, confirm the safe working range of motor and mechanical equipment before running; otherwise, personal injuries and equipment damages may be caused.
	3. If necessary, install a band-type brake separately; otherwise, person injuries will be caused.
	4. Don't change wiring during operation; otherwise, the equipment or frequency inverter will be damaged.

In order to ensure safety, mechanical coupler shall be unhooked before initial running, so that the motor can separate from mechanical equipment. If the motor and mechanical equipment are coupled before the initial running, special attention should be paid in to prevent possible dangers. Inspect the following contents before test run:

- A Whether leads and terminals are connected correctly.
- B Whether there is lead residues that may cause short circuit.
- C Whether screw terminals are tightened firmly.
- D Whether the motor is installed firmly.

4.2.2 Test Run

When the system gets ready, turn on power supply and inspect whether the frequency inverter is normal. Digital operation keyboard is lighted up when the power supply is turned on. If any problem is found, turn off the power supply immediately.

After the power supply is turned on, the frequency inverter operates automatically (default factory settings) after a 30-second delay. Observe water outlet of water pump. If the quantity of outlet water is normal, then the test run succeeds; if it is low, exchange two motor wires randomly and then run again.

4.3 Keyboard Operation Method

4.3.1 Keys and functions of keyboard

(1) Keys and functions of keyboard



Name	Description	
Status indicator lamp	FWD	Light off means the frequency inverter runs forward; light on means the frequency inverter runs backward.
	RUN	frequency inverter is running when it is on
	TUNE	Keyboard start: TUNE light normally off Auto start and terminal start: TUNE light blinks Reserved: TUNE light normally on
Unit indicator lamp	V	Indicate voltage value
	A	Indicate current value
	Hz	Indicate frequency value
	V-%-A	Indicate percentage
	A-RPM-Hz	Indicate rotating speed
Key area	MODE	Switch display mode; cancel data modification
	ENTER	Reads and stores parameter when it is set.
	▲	Functional code selection; data addition and subtraction setting
	▼	
	>>>	When the parameter is displayed in cycle in the power-off display interface and running display interface, this key can display a certain parameter in a fixed manner. When it is pressed again, cycle display will be recovered. When parameters are modified, it can be used to select the modification bit.
	JOG	Multi-functional key
	RUN	Running key
STOP/RESET	Stop and reset key	

Chapter IV Keyboard Operation and Running

(2) Keyboard 1:



Keyboard dimensions: 65 mm*50 mm

Keyboard seat installation dimensions: 77.5*59 mm

Keyboard seat dimensions: 83.5*65 mm

Keyboard 3 is the standard configuration for frequency inverter model 1~4

(3) Keyboard 2:



Keyboard dimensions: 63 mm*75 mm

Keyboard seat installation dimensions:99*70mm

Keyboard seat dimensions:107*80mm

Keyboard 3 is the standard configuration for frequency inverter model 5

(4) Keyboard 3:



Keyboard dimensions: 117 mm*68 mm

Keyboard seat installation dimensions:136*72mm

Keyboard seat dimensions:142*78mm

Keyboard 3 is the standard configuration for frequency inverter model 6 and above

Chapter IV Keyboard Operation and Running

4.3.2 Methods to view/give parameters (with digital keyboard)

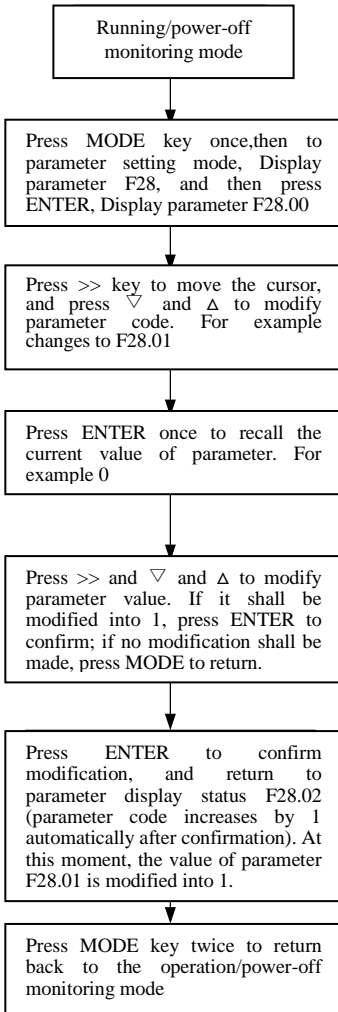

E.g.: Below is the example of modifying the parameter

F28.03 of start waiting time from 1 to 2

1	Running/power-off monitoring mode	Display Running/power-off monitoring mode. Press MODE key to enter parameter setting mode. Display parameter F28, and then press ENTER, Display parameter F28.00
2	F28.00	Display parameter F28.00, and at the same time, the pointer blinks at the last data bit "0". Press ∇ and Δ to select the functional code to set, and press >> to move the data bit.
3	F28.03	Press Δ to modify the display value into F28.03, and then press ENTER.
4	1	View whether the factory default of parameter is 1, and whether the pointer points at data bit "1".
5	2	Modify the display value of Δ key into 2, and then press ENTER.
6	F28.04	Write 2 for data saving. The start waiting time for parameter display has been modified from 30s into 60s. At this moment, return to parameter display of F28.04.
7	F28.03	If MODE is pressed directly without pressing ENTER key in the 5 th step, the keyboard will return to parameter display of F28.03, and data modification will not be saved, and the acceleration time stays at 30 s without change.
8	operation/power-off monitoring mode	Press MODE key twice to return to the operation/power-off monitoring mode.

Cautions: Data cannot be modified in any of the following situations.

1. Parameters cannot be adjusted when the frequency inverter is running. (See Functional Parameters Table)

Chapter IV Keyboard Operation and Running

4.3.3 Keyboard monitoring data

When inverter waiting, keypad will show in turn

Solar panel DC voltage
Biggest frequency
Output current

When inverter running, keypad will show in turn

Solar panel DC voltage
Output frequency
Output current

When the parameter is displayed in cycle on power-off display interface and operation display interface, press **>>** this key to show a certain parameter permanently, and press it again to recover the cycle display. When parameters are modified, parameter modification bit can be selected.

Chapter V Functional Parameters Table

Description of functional parameters table:

1. The Product's functional code, F28 Group, contains several subgroups. Within each subgroup, there are several functional codes the value of which can be set as different values.

2. If F×××× occurs to the table and other content of the Manual, it means the functional code numbered "××" of the subgroup numbered "××"; e.g. "F28.01" refers to 01 functional code of F28 subgroup.

3. Line content of the table is described as below:

The 1st line "functional code": The number of functional code parameter; the 2nd line "name": Complete name of functional code parameter; the 3rd line "given range": The range of the effective given values of functional code parameter; the 4th line "factory default": Original factory default of the functional code parameter; the 5th line "modification restrictions": Modification attribute of functional code parameter (i.e. whether it is allowed to modify and modification conditions).

Restrictions on the modification of functional code parameters are described as below:

“☆”: The given value of this parameter can be modified either in the shutdown or running status of the Product.

“★”: The given value of this parameter cannot be modified when the Product is running.

“●”: The value of this parameter is the actually tested value and cannot be modified.

Note:

Users shall read the Manual carefully while modifying the parameters of frequency inverter. If you want to use the special function of the Product but cannot understand, you can contact our Technical Department. We will provide safe and reliable technical support service for you. Please don't modify data at will; otherwise, serious failures might be caused, leading to serious property losses. User's failure to observe this warning shall be at your own risk.

Chapter V Functional Parameters Table

5.1 Basic Functions of F28 Group

Functional Code	Name	Given Range	Factory Default	Modification Restrictions
F28.00	Software ver.	/	/	●
F28.01	Starting mode	0: keyboard start; 1: auto start 2: terminal start 3:Reserved	1	☆
F28.02	Operation mode	0: MPPT mode 1: CVT mode 2: debugging mode 3: universal mode of frequency inverter	0	★
F28.03	Start waiting time	0.10S 1.30S 2.60S 3.90S 4.180S 5.300S 6.600S 7.1200S 8.1800S	1	☆
F28.04	Maximum frequency	0.60Hz; 1.50Hz.	1	★
F28.05	Low-frequency protection	0.45Hz; 1.40Hz; 2.35Hz; 3.30Hz; 4.25Hz; 5.20Hz; 6.15Hz; 7.10Hz。	2	☆
F28.06	Low-frequency time	0-65535S	60	☆
F28.07	Low-frequency reset	0-65535S	600	☆
F28.08	Fault reset time	0-6553.5S	600	☆
F28.09	Number of resets	0-65535	10	☆
F28.10	Under-voltage setting	0-400V	T4:270V T2、SS2、S2:170V	☆
F28.11	Over-voltage setting	0-950V	T4:800V T2、SS2、S2: 450V	☆
F28.12	Full water level delay	0-1000S	5	☆
F28.13	Wakeup delay upon full water level	0-1000S	20	☆
F28.14	Empty water level delay	0-1000S	5	☆
F28.15	Wakeup delay upon empty water level	0-1000S	20	☆

Chapter V Functional Parameters Table

Functional Code	Name	Given Range	Factory Default	Modification Restrictions
F28.16	CVT voltage	0-1000V	0	☆
F28.17	Voltage of debugging mode	0-1000V	0	☆
F28.18	Rated power of motor	/	Model	●
F28.19	Rated voltage of motor	/	Model	●
F28.20	Rated current of motor	/	Model	●
F28.21	Rated speed of motor	/	Model	●
F28.22	Instant recovery	0. No action; 1. Recover to the default.	0	★
F28.24	Acceleration time	/	15	☆
F28.25	Deceleration time	/	10	☆
F28.26	Timing function	0-65535h	0	☆
F28.27	Password protection	0-65535	0	☆
F28.28	Inversion temperature	/	/	●
F28.29	Frequency reduction temperature	0-95℃	82	☆
F28.30	Under-load protection	0: No protection; 1. Start protection.	0	☆
F28.31	Under-load current	0-6553.5A	Model	☆
F28.32	Under-load time	0-6553.5S	60	☆
F28.33	Under-load reset	0-6553.5S	600	☆
F28.39	Single phase mode	0. No start; 1. Start.	0	★
F28.40	Power down and frequency reduction	0. No start; 1. Start.	0	☆
F28.41	Frequency decrease rate	0-50.00Hz	3	☆
F28.42	The last failure	/	/	●
F28.43	The second to last failure	/	/	●
F28.44	The third to last failure	/	/	●
F28.45	The fourth to last failure	/	/	●
F28.46	The fifth to last failure	/	/	●
F28.49	Power setting	0.4-185.0kW	Model	●

Chapter V Functional Parameters Table

F28.02: Operation Mode

0. In MPPT mode, the frequency inverter turns power down and frequency reduction function; its final voltage upon start tracks from 80% open-circuit voltage, and the efficiency is above 98%. When luminous energy is adequate and stable, the output frequency fluctuates within 1 Hz. In non-MPPT mode, any other parameters can be modified. To start in this mode, for a steady operation, the output frequency can be fixed at 35 Hz, and then raise frequency when the energy becomes steady. Alternatively, keep steady voltage mod from the beginning and fix bus voltage at about 270 V and let the frequency rise slowly. The minimum tracking voltage of MPPT must be higher than under-voltage failure 10 V;

1. In CVT mode, there is only PV panel input, It requires testing the bus voltage before starting and regarding 80% open-circuit voltage as the stabilized voltage directly.

2. Internal debugging mode

3. In the mode of universal frequency inverter, turn off the PV MPPT function and use the frequency inverter as a universal one. The frequency inverter operates in VF mode.

Chapter VI Troubleshooting

Failure	Description	Detail	Troubleshooting
OUt1	U phase protection of inverter unit	Too fast acceleration; Damage of IGBT; Mis-operation caused by inference; Poor connection of driving line; whether it is short circuit to ground	Increase acceleration time; replace power unit; Inspect the driving line; Inspect if there is strong interference source to the peripheral equipment
OUt2	V phase protection of inverter unit		
OUt3	W phase protection of inverter unit		
OV1	Acceleration over-voltage	Abnormal input voltage; Large energy feedback; Loss of braking assembly; Energy consumption braking function is not on	Inspect the input power supply; Inspect if the load deceleration time is too short, or the motor starts during rotation; Add energy consumption braking assemblies; Inspect the setting of relevant functional codes
OV2	Deceleration over-voltage		
OV3	Constant-speed over-voltage		
OC1	Acceleration over-current	Too fast acceleration or deceleration; Grid voltage is relatively low; PV pump driver power is relatively small; A sudden load change or abnormal load; short circuit to ground; Phase loss of input; Have strong source of interference on the outside; Overvoltage stall protection is not on	Inspect acceleration and deceleration time; Inspect input power supply; Select a higher power level PV pump driver; Inspect if short circuit (short circuit to ground or line-to-line short circuit) or locked-rotor occurs to the load; Inspect output wiring; Inspect if there is strong interference source; Inspect the setting of relevant functional codes.
OC2	Deceleration over-current		
OC3	Constant-speed over-current		
UV	Bus over-voltage fault	Grid voltage is relatively low; Overvoltage stall protection is not on	Inspect the input power supply of power grid; Inspect the setting of relevant functional codes
OL1	Motor overload	Low grid voltage; Incorrect setting of the rated current of motor; Locked-rotor or too large sudden load change of motor	Inspect grid voltage; Set the rated current of motor again; Inspect load and adjust torque boost
OL2	PV pump driver overload	Too fast acceleration; restart of running motor; Low grid voltage; Too large load; Mismatching of drive and load	Increase acceleration time; Avoid downtime and restart; Check grid voltage; Inspect grid voltage; Select a higher power level PV pump driver;
SPI	Phase loss in input terminal	Phase loss or large phase fluctuation upon the input of R, S and T.	Inspect the input power supply; inspect the installed wires
SPO	Phase loss in output terminal	Phase loss output of U, V and W (or serious asymmetry of the 3 phases of load)	Inspect the output wiring; inspect motor and cable

Chapter VI Troubleshooting

Failure	Description	Details	Troubleshooting
OH1	Overheat of rectification module	Blocked air duct or damaged fan; Environmental temperature too high;	Dredge the air duct or replace the fan; Reduces environmental temperature for overheat fault of OH2 inverter module;
OH2	Overheat of inverter module	Over-load operation too long time .	
EF	External fault	DI external fault input terminal acts;	Inspect the input of external equipment
END	Running time is up	The actual running time of the Product is longer than the internally set running time	Seek suppliers to help adjust set run time
OL3	Electronic overload fault	Overload warning of the Product is given according to the set value	Inspect load and over-load warning point
ETH1	Short circuit to ground fault 1	The output of the Product is short circuited to ground; current testing circuit is failed	Inspect whether motor wiring is normal; replace Hall; replace the main control panel
ETH2	Short circuit to ground fault 2		
LL	Electronic underload fault	The inverter will report the underload pre-alarm according to the set value.	Check the load and the underload pre-alarm point.
PINV	PV reverse connection fault	Incorrect PV wiring	Change the wiring direction of the positive and negative terminals and connect the cables again.
PVOC	PV overcurrent	<ol style="list-style-type: none"> 1. The acceleration or deceleration is too fast. 2. The inverter power is too low. 3. The load transients or is abnormal. 4. The grounding is short circuited. 	<ol style="list-style-type: none"> 1. Increase the ACC or DCC time. 2. Select the inverter with a larger power. 3. Check if the load is short circuited (the grounding short circuited or the wire short circuited) or the rotation is not smooth.
PVOV	PV overvoltage	<ol style="list-style-type: none"> 1. The solar cell panel input voltage is too high. 2. Model -4 is set as another model. 	<ol style="list-style-type: none"> 1. Reduce the number of solar cell panels that are wired in series. 2. Check and reset the model.
PVLV	PV undervoltage	<ol style="list-style-type: none"> 1. The power of the solar cell panel series is too low or it is cloudy and rainy weather. 2. The motor start-up current is too high. 	<ol style="list-style-type: none"> 1. Increase the number of solar cell panels or perform the test in the normal sun light. 2. Change the motor.
A-LS	Weak light warning	Weak solar irradiance, or too little configuration of cell panel	After the light is strong, the device will run automatically, and the user does not need to pay attention; please inspect if the configuration of cell panel is reasonable.
A-LL	Under-load warning	Empty suction basin	Check the pumping pool

Chapter VI Troubleshooting

A-tF	Water fullness warning	Full reservoir	If the user sets water fullness alarm function; the equipment will shut down automatically when the warning is on for a certain period of time, and the user needs not to notice it; otherwise, please check if the terminal wiring is wrong.
A-tL	Waterempty warning	Empty suction basin	If the user sets water empty alarm function; the equipment will shut down automatically when the warning is on for a certain period of time, and the user needs not to notice it; otherwise, please check if the terminal wiring is wrong.

Appendix 1 Recommended Configuration of Solar Cell Modules

Appendix 1 Recommended Configuration of Solar Cell Modules

Product Model	Open-circuit Voltage Class of Solar Cell Module			
	37±1V		45±1V	
	Module Power ±5 Wp	Number of each string of modules * number of strings	Module power ±5 Wp	Number of each string of modules * number of strings
CDI-SPDG0R4SS2	250	11*1	300	9*1
CDI-SPDG0R7SS2	250	11*1	300	9*1
CDI-SPDG1R5SS2	250	11*1	300	9*1
CDI-SPDG2R2SS2	250	11*1	300	9*1
CDI-SPDG4R0SS2	250	11*2	300	9*2
CDI-SPDG0R4S2	250	11*1	300	9*1
CDI-SPDG0R7S2	250	11*1	300	9*1
CDI-SPDG1R5S2	250	11*1	300	9*1
CDI-SPDG2R2S2	250	11*1	300	9*1
CDI-SPDG4R0S2	250	11*2	300	9*2
CDI-SPDG4R0T2	250	11*2	300	9*2
CDI-SPDG0R7T4	250	18*1	300	15*1
CDI-SPDG1R5T4	250	18*1	300	15*1
CDI-SPDG2R2T4	250	18*1	300	15*1
CDI-SPDG4R0T4	250	18*2	300	15*2
CDI-SPDG5R5T4	250	18*2	300	15*2
CDI-SPDG7R5T4	250	18*2	300	15*2
CDI-SPDG011T4	250	18*3	300	15*3
CDI-SPDG015T4	250	18*4	300	15*4
CDI-SPDG018.5T4	250	18*5	300	15*5
CDI-SPDG022T4	250	18*6	300	15*6
CDI-SPDG030T4	250	18*8	300	15*8
CDI-SPDG037T4	250	18*10	300	15*10
CDI-SPDG045T4	250	18*12	300	15*12
CDI-SPDG055T4	250	18*15	300	15*15
CDI-SPDG075T4	250	18*20	300	15*20
CDI-SPDG090T4	250	18*25	300	15*25
CDI-SPDG110T4	250	18*30	300	15*30